



dbAccess
AutoTech Conference

Jens van Eikels

Head of e-tron next generation

AUDI AG | November 10th, 2020 | 13:00 CEST

Disclaimer

The following presentations contain forward-looking statements and information on the business development of the Audi Group. These statements may be spoken or written and can be recognized by terms such as “expects”, “anticipates”, “intends”, “plans”, “believes”, “seeks”, “estimates”, “will” or words with similar meaning. These statements are based on assumptions, which we have made on the basis of the information available to us and which we consider to be realistic at the time of going to press. These assumptions relate in particular to the development of the economies of individual countries and markets, the regulatory framework and the development of the automotive industry. Therefore the estimates given involve a degree of risk, and the actual developments may differ from those forecasts. The Audi Group currently faces additional risks and uncertainty related to pending claims and investigations in a number of jurisdictions in connection with findings of irregularities relating to exhaust emissions from diesel engines in certain Audi Group vehicles. The degree to which the Audi Group may be negatively affected by these ongoing claims and investigations remains uncertain. The recent outbreak of COVID-19 (commonly referred to as coronavirus) has negatively impacted and may continue to impact economic and social conditions in some of Audi's primary markets, including China and Europe, as public, private, and government entities implement containment and quarantine measures. The continued spread of COVID-19 may cause shortages of necessary materials and parts from suppliers directly or indirectly affected by the outbreak and may cause operational disruptions and interruptions at Audi's production facilities, leading to significant production downtimes. A negative development relating to ongoing claims or investigations, the continuation of COVID-19, an unexpected fall in demand or economic stagnation in our key sales markets, such as in Western Europe (and especially Germany) or in the USA, Brazil or China, and trade disputes among major trading partners will have a corresponding impact on the development of our business. The same applies in the event of a significant shift in current exchange rates in particular relative to the US dollar, sterling, yen, Brazilian real, Chinese renminbi and Czech koruna. If any of these or other risks occur, or if the assumptions underlying any of these statements prove incorrect, the actual results may significantly differ from those expressed or implied by such statements. We do not update forward-looking statements retrospectively. Such statements are valid on the date of publication and can be superseded. This information does not constitute an offer to exchange or sell or an offer to exchange or buy any securities.

After establishing Audi as credible BEV brand with e-tron, in 2021 Audi is making an important step towards scaled e-mobility with Audi Q4 e-tron.



As the first German premium OEM Audi has brought a full-size electric SUV to the market.

e-tron

THE PIONEER



e-tron



e-tron Sportback



e-tron S



e-tron Sportback S

STRATEGIC RATIONALE



Time to Market - first mover in premium segment among classical OEMs



Establishing **Audi as a BEV manufacturer**



C-Segment car with higher transaction price



Substantial contribution to cover investments



Lever to achieve **CO₂-Targets**

PRODUCT HIGHLIGHTS E-TRON SB¹⁾



Virtual mirrors & digital matrix light



up to **440+ km** (WLTP) // 95 kWh



Recuperation system, up to 30% range contribution



150 kW charging over longer periods of time (to 80% in < 30 min)

¹⁾ based on e-tron Sportback 55 Quattro

» The quietest, smoothest electric car I've ever driven. This is Audi laying down a marker for those that follow.«

topgear.com, 03/2019

»Electric car market share hits record high in Norway, Audi e-tron is leading the pack«

electrek.com, 07/2020

»Fast charging and long-distance qualities as a trump card«

electrek.com, 07/2020

»Audi e-tron is world market leader in its segment«

automotiveworld.com, 07/2020



Press Feedback

Audi e-tron S Sportback: Combined electric power consumption in kWh/100 km: 28.1-26.4 (WLTP); 27.6-27.5 (NEDC);
Combined CO₂ emissions in g/km: 0

Over 58k customers have chosen an Audi e-tron. Regional success highly influenced by market specific attractiveness of BEVs – Norway leads the way.

Deliveries to customers

Audi e-tron family in k units

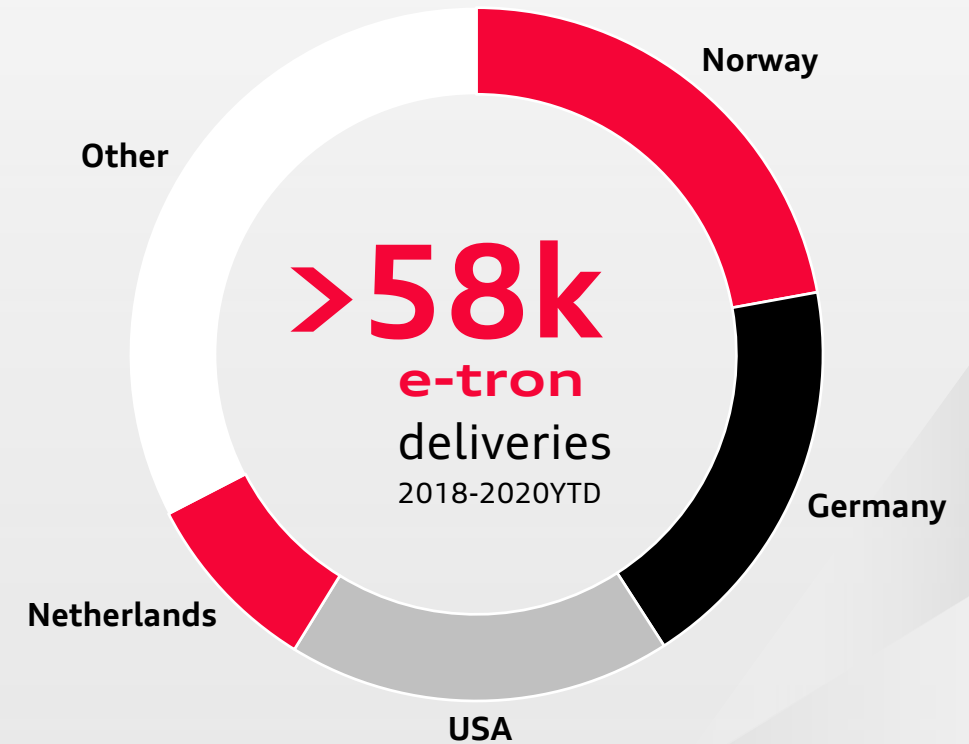
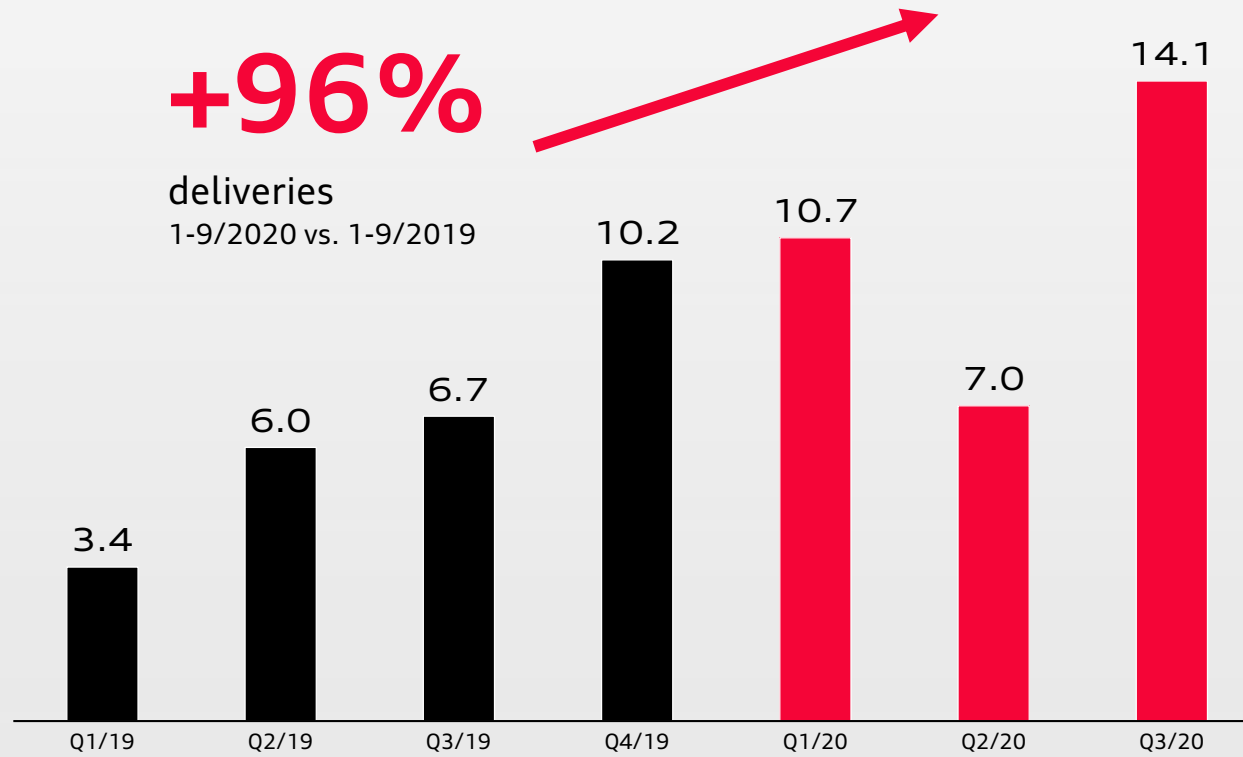

Dedicated BEV platforms shared across VW Group brands enable us to benefit from scale advantages, offering uncompromising BEVs in relevant segments.

MLBevo



J1



MEB ~20m vehicles by 2029¹⁾



PPE ~6m vehicles by 2029¹⁾



D



more to come...



C

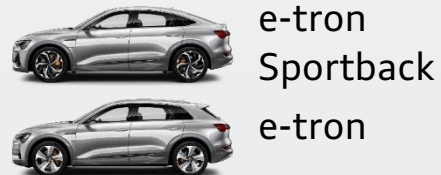

flat-floor sedan



B

more to come...



mid-size SUV



A



SEGMENT

1) across all brands of the VW Group



Audi e-tron GT

concept

e-tron GT will emotionally charge the definition of an e-tron – an even sportier RS version will follow.

e-tron GT

THE BRAND SHAPER



STRATEGIC RATIONALE



brand shaper



celebration of **Audi design**



emotional charging of the e-tron brand (analogue to R8, TT)



scaling of Porsche's J1 platform

PRODUCT HIGHLIGHTS E-TRON GT¹⁾



> 434 kW (590 PS)



top speed **240 km/h**

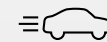

3.5s 0 → 100 km/h



400+ km (WLTP) // 90+ kWh



800 V enables quicker charging (to 80% in 20 min)



Recuperation system, up to 30% range contribution



Market introduction **spring 2021**

*concept
more with RS version*

¹⁾ Figures based on concept cars, actual series model may differ.



Q4 Sportback e-tron

concept

As the first Audi based on MEB platform, Q4 e-tron will democratize premium electric mobility.

Q4 e-tron

THE ACCESSIBLE E-TRON



STRATEGIC RATIONALE

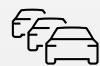

democratization of electric mobility



attractive price for an **attractive car**



cost depression thanks to **higher volumes**



ensuring **long-term CO₂ compliance**

PRODUCT HIGHLIGHTS Q4 E-TRON¹⁾



225 kW (306 PS)

concept



top speed **180 km/h**

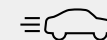

6.3s 0 → 100 km/h



up to **500+ km** (WLTP) with RWD // 82kWh



up to **125kW** charging
(to 80% in under 40 min)







Market introduction **2021**.





¹⁾ Figures based on concept cars, actual series model may differ.

MEB offers flexible architecture with consistent matrix kit:
over 20 different models will be based on the platform.

Platform synergies

 ↔	6 Wheelbase variants		3 Wheel ø variants
 ↔	3 Axle track variants	 ↑ ↓	5 Matrix seat height options
	1 cell option	7	battery modules

Top hat synergies

	Windshield measurements
	Roof frame
	Dashboard
	DAS sensor positioning

over
20
models
across VW Group



Multi-brand factories reduce investment requirements, provide flexibility, as well as optimized processes and logistics networks.

MEB   **SEAT**



ZWICKAU

6 MODELS

- Efficient plant allocation
- Flexibility
- Investment synergies
- Productivity improvements
- Speed up ramp up phase
- Exploiting benefits of reduced complexity
- Infrastructure optimization
- Optimized supplier structure

PPE-based vehicles will address C- and D-segments, bringing performance and design to the next level.

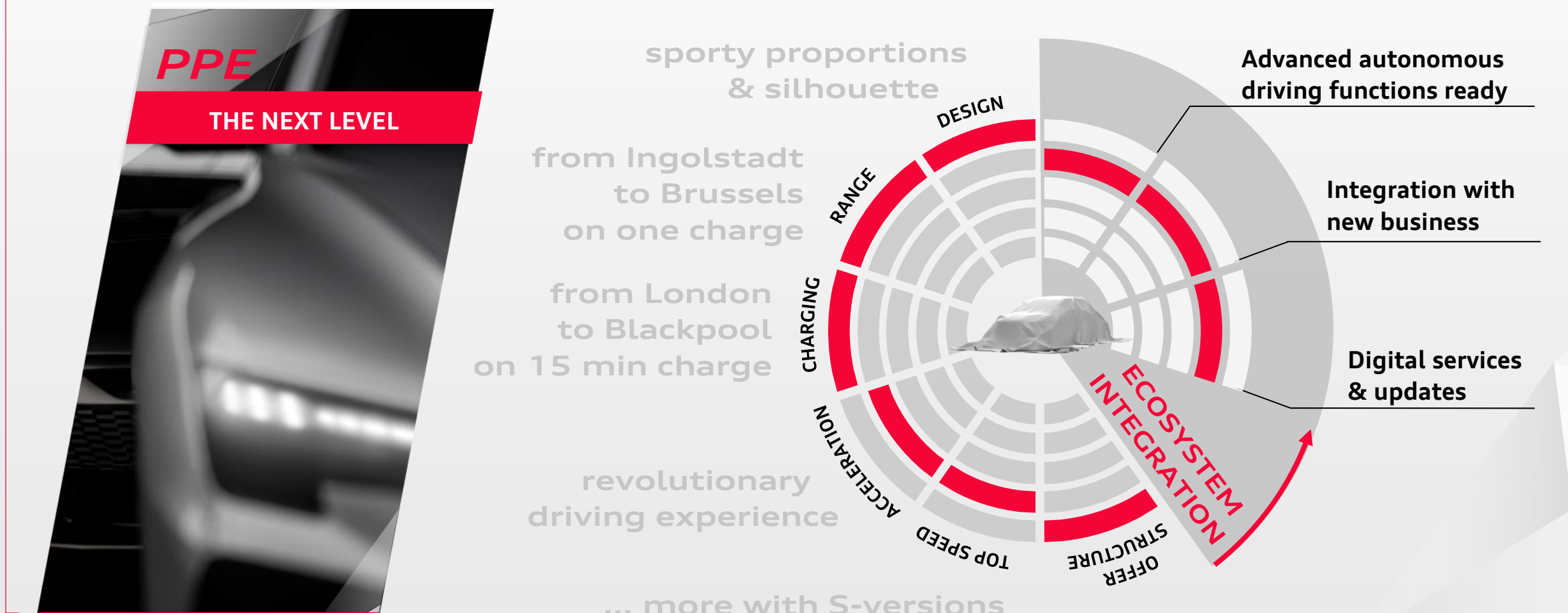

Major improvements in e-axle parameters result from know-how ramp up and the learnings thanks to in-house development.

e-tron electric front axle

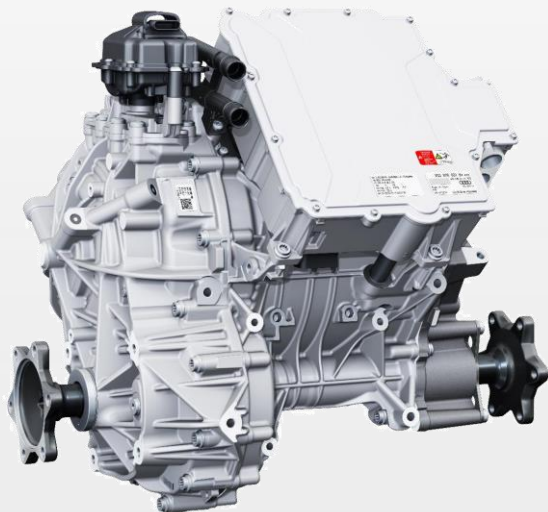

comparable PPE electric front axle

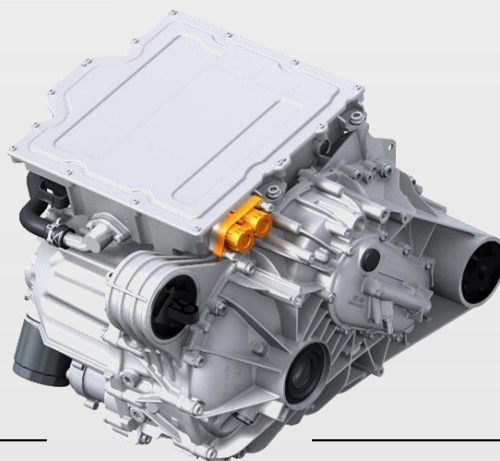

e-axle box dimensions

— ~30%



e-axle weight

— ~20%



e-motor dimensions

— ~35%



e-axle performance

+ ~18%



e-axle efficiency loss

halved



contribution to range improvement

+ ~10%

Just as MEB, PPE-team strongly focuses on design-to-cost and aims for high share of carry-over-parts.

COP

~ 90%
entire vehicle

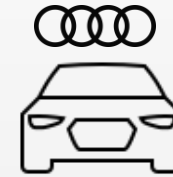

SYNERGIES IN CURRENT PORTFOLIO

SYNERGIES WITH SISTER BRANDS

SYNERGIES FOR DERIVATIVES / FOLLOWING PROJECTS

Audi Mid Size SUV
(1st SUV on PPE)

Macan BEV

next Audi SUV Derivative

Audi Mid Size SUV
Long Wheel Base

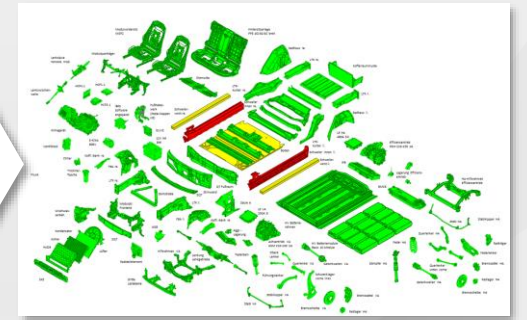
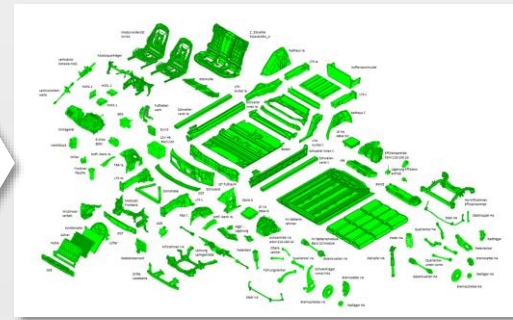
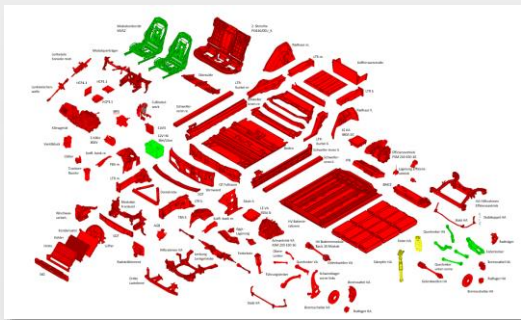

Example: Platform

To exploit all the benefits shared architectures offer, we define synergy clusters in top hut across whole portfolio and across multiple brands.

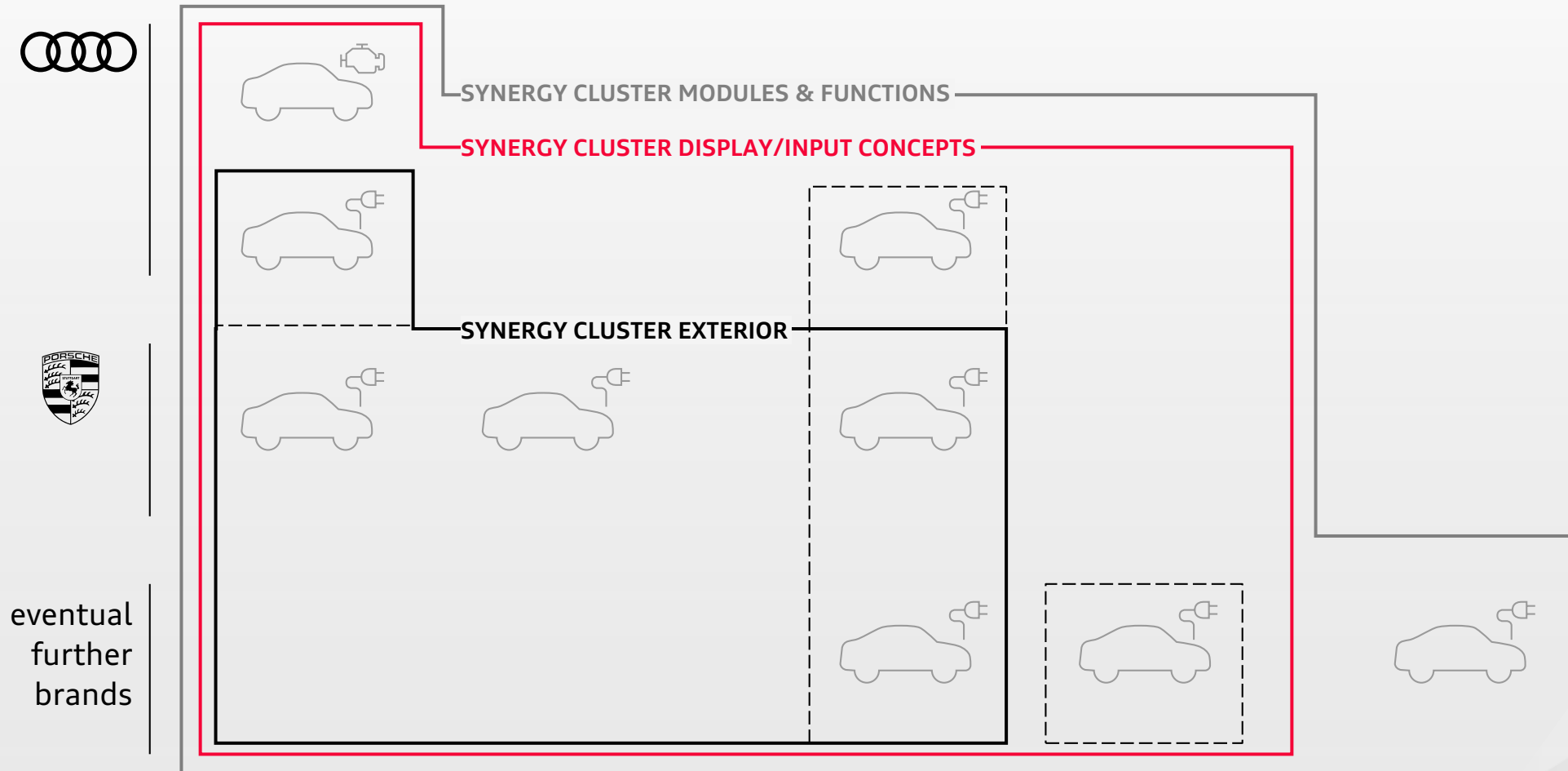

With the Artemis Project we rapidly integrate solutions across VW Group to develop the new generation high performance model by 2024.

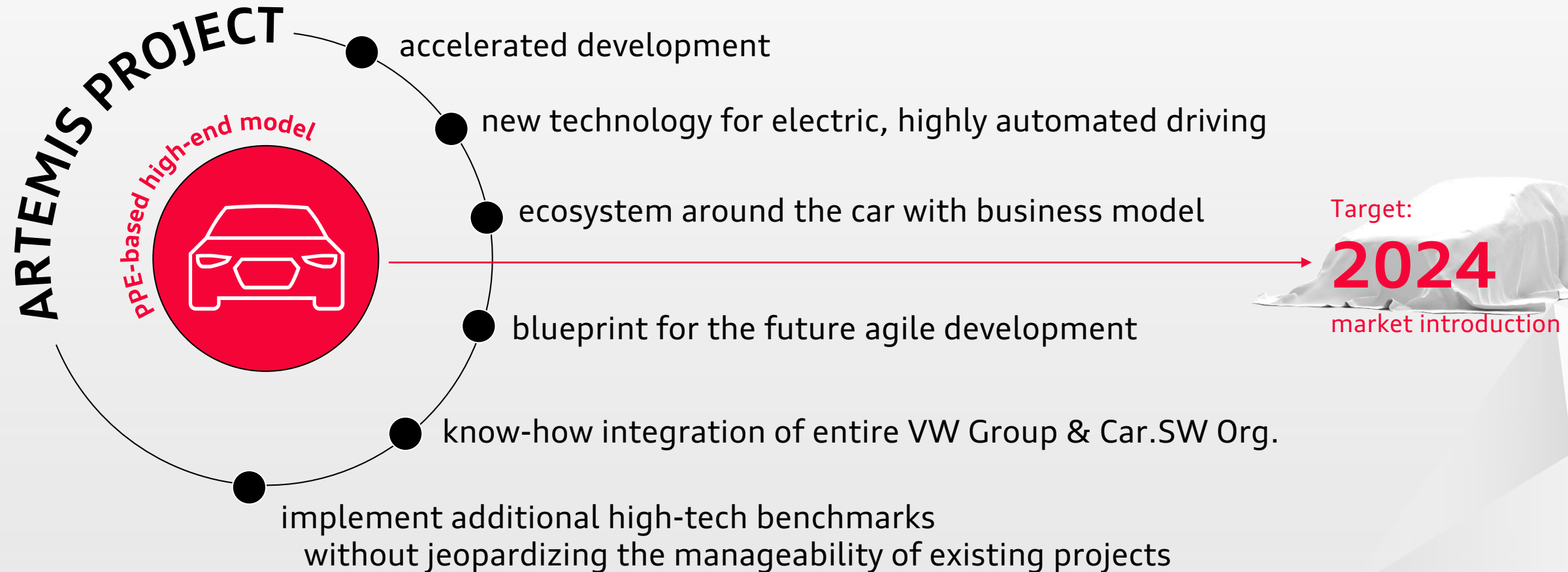



The specified fuel consumption and emission data have been determined according to the measurement procedures prescribed by law. Since 1st September 2017, certain new vehicles are already being type-approved according to the Worldwide Harmonized Light Vehicles Test Procedure (WLTP), a more realistic test procedure for measuring fuel consumption and CO₂ emissions. Starting on September 1st 2018, the New European Driving Cycle (NEDC) will be replaced by the WLTP in stages. Owing to the more realistic test conditions, the fuel consumption and CO₂ emissions measured according to the WLTP will, in many cases, be higher than those measured according to the NEDC. Therefore, the usage of CO₂ emission values measured according to WLTP for vehicle taxation from 1st September 2018 on can cause changes in this regards as well. For further information on the differences between the WLTP and NEDC, please visit www.audi.de/wltp.

We are currently still required by law to state the NEDC figures. In the case of new vehicles which have been type-approved according to the WLTP, the NEDC figures are derived from the WLTP data. It is possible to specify the WLTP figures voluntarily in addition until such time as this is required by law. In cases where the NEDC figures are specified as value ranges, these do not refer to a particular individual vehicle and do not constitute part of the sales offering.

They are intended exclusively as a means of comparison between different vehicle types. Additional equipment and accessories (e.g. add-on parts, different tyre formats, etc.) may change the relevant vehicle parameters, such as weight, rolling resistance and aerodynamics, and, in conjunction with weather and traffic conditions and individual driving style, may affect fuel consumption, electrical power consumption, CO₂ emissions and the performance figures for the vehicle.

For further information on the official fuel consumption and official specific CO₂ emissions of new cars, please refer to the "Guide to the fuel and energy consumption and CO₂ emissions of new cars", which is available free of charge at all points of sale and from Deutsche Automobil Treuhand GmbH, Hellmuth-Hirth-Str. 1, D-73760 Ostfildern or under www.dat.de.

Die angegebenen Verbrauchs- und Emissionswerte wurden nach den gesetzlich vorgeschriebenen Messverfahren ermittelt. Seit dem 1. September 2017 werden bestimmte Neuwagen bereits nach dem weltweit harmonisierten Prüfverfahren für Personenwagen und leichte Nutzfahrzeuge (Worldwide Harmonized Light Vehicles Test Procedure, WLTP), einem realistischeren Prüfverfahren zur Messung des Kraftstoffverbrauchs und der CO₂-Emissionen, typgenehmigt. Ab dem 1. September 2018 wird der WLTP schrittweise den neuen europäischen Fahrzyklus (NEFZ) ersetzen. Wegen der realistischeren Prüfbedingungen sind die nach dem WLTP gemessenen Kraftstoffverbrauchs- und CO₂-Emissionswerte in vielen Fällen höher als die nach dem NEFZ gemessenen. Dadurch können sich ab 1. September 2018 bei der Fahrzeugbesteuerung entsprechende Änderungen ergeben. Weitere Informationen zu den Unterschieden zwischen WLTP und NEFZ finden Sie unter www.audi.de/wltp.

Aktuell sind noch die NEFZ-Werte verpflichtend zu kommunizieren. Soweit es sich um Neuwagen handelt, die nach WLTP typgenehmigt sind, werden die NEFZ-Werte von den WLTP-Werten abgeleitet. Die zusätzliche Angabe der WLTP-Werte kann bis zu deren verpflichtender Verwendung freiwillig erfolgen. Soweit die NEFZ-Werte als Spannen angegeben werden, beziehen sie sich nicht auf ein einzelnes, individuelles Fahrzeug und sind nicht Bestandteil des Angebotes. Sie dienen allein Vergleichszwecken zwischen den verschiedenen Fahrzeugtypen. Zusatzausstattungen und Zubehör (Anbauteile, Reifenformat usw.) können relevante Fahrzeugparameter, wie z. B. Gewicht, Rollwiderstand und Aerodynamik verändern und neben Witterungs- und Verkehrsbedingungen sowie dem individuellen Fahrverhalten den Kraftstoffverbrauch, den Stromverbrauch, die CO₂-Emissionen und die Fahrleistungswerte eines Fahrzeugs beeinflussen.

Weitere Informationen zum offiziellen Kraftstoffverbrauch und den offiziellen spezifischen CO₂-Emissionen neuer Personenkraftwagen können dem „Leitfaden über den Kraftstoffverbrauch, die CO₂-Emissionen und den Stromverbrauch neuer Personenkraftwagen“ entnommen werden, der an allen Verkaufsstellen und bei der DAT Deutsche Automobil Treuhand GmbH, Hellmuth-Hirth-Str. 1, D-73760 Ostfildern oder unter www.dat.de unentgeltlich erhältlich ist.